

CREATELED®

AirMAGLITE-V2

Quick and Easy to Build LED Walls

Super Lightweight
High Definition Outdoor Display
Quick and Easy Operation
Ideal for rental Applications



Super Lightweight

- › Carbon fiber and magnesium alloy frame with high durability, the super light AirMAGLITE-V2 weighs 18.6 kg/m².
- › Dimensions: 500 mm x 1,000 mm x 81 mm/500 mm x500 mm x81 mm

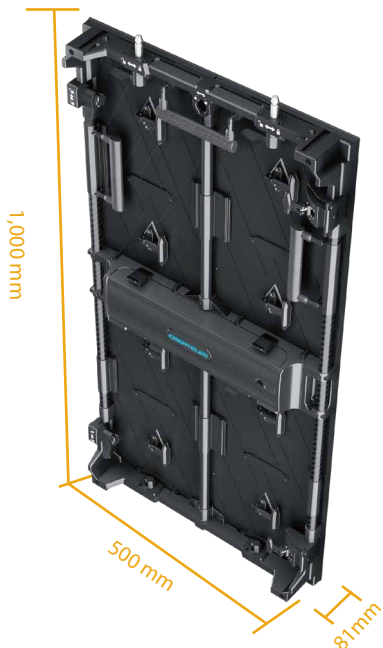

Easy to Install

- › Back serviceable, the installation of LED wall is quick, accurate and easy to service.
- › The AirMAGLITE-V2 is flexible for hanging, stacking, wall mount and ceiling.
- › Automatically locking with Up and Down panel, single person fastly operating. The lock can fix the pin location automatically, only one person can operate the panels connection very easily, simple procedures.
- › Support Stacking installation



High Definition with Curving Function

- › Available in screen curving, Ideal to build large LED wall in a curve and other application field.

AirMAGLITE-V2 / Specifications

	AirMAGLITE-V2-2.9*	AirMAGLITE-V2-3.9	AirMAGLITE-V2-3.9
Physical Pitch	2.9 mm	3.9 mm	3.9 mm
Pixel Configuration	SMD	SMD	SMD
Pixel Density	112,896 pixels/m ² 56,448 pixels/panel	65,536 pixels/m ² 32,768 pixels/panel	65,536 pixels/m ² 32,768 pixels/panel
Module Dimensions (mm)	250 × 500	250 × 500	250 × 500
Panel Dimensions (W × H × D) (mm)	500 × 1,000 × 81	500 × 1,000 × 81	500 × 1,000 × 81
No. of Modules Per Panel (W × H)	2 × 2	2 × 2	2 × 2
Physical Resolution of Module (W × H)	84 × 168	64 × 128	64 × 128
Physical Resolution of Panel (W × H)	168 × 336	128 × 256	128 × 256
Weight Per Panel	8.7±0.3 kg/panel	8.7±0.3 kg/panel	9.3±0.3 kg/panel
Weight Per m ²	17.4±0.6 kg/m ²	17.4±0.6 kg/m ²	18.6±0.6 kg/m ²
Angle	-10°,0°,±5°	-10°,0°,±5°	-10°,0°,±5°
Processing	14-16 bit	14-16 bit	14-16 bit
Colours	281 trillion	281 trillion	281 trillion
Contrast Ratio	4,000 : 1	4,000 : 1	3,000 : 1
Average Power Consumption	100 - 120 w/panel	100 - 120 w/panel	110 - 165 w/panel
Power Consumption (Max)	240w/panel	240w/panel	330 w/panel
Operating Temp/Humidity	-10 - 40°C / 10% - 80%	-10 - 40°C / 10% - 80%	-20 - 50°C / 10% - 90%
Storage Temp/Humidity	-20 - 60°C / 10% - 90%	-20 - 60°C / 10% - 90%	-30 - 60°C / 10% - 95%
Brightness	1200 nits	1200 nits	4500 nits
Refresh Rate	3,840 Hz	3,840 Hz	3,840 Hz
Horizontal Viewing Angle	160°	160°	140°
Vertical Viewing Angle	120°	120°	120°
Expected LED Lifetime (Max)	100,000 Hrs	100,000 Hrs	100,000 Hrs
Max Hanging	16 panels	16 panels	16 panels
Servicing	front and Back	front and Back	front and Back
IP Rating	IP 30	IP 30	IP 65
Certification	CE*, EMC ClassA*,ETL*, RoHS*,CCC*	CE*, EMC ClassA*,ETL*, RoHS*,CCC*	CE*, EMC ClassA*,ETL*, RoHS*,CCC*

*Notes: The Specifications are for reference; actual values may vary.
Shenzhen CreateLED Electronics Co.,Ltd reserves the right to modify product design, specifications,
and parameters without further notice.

Application Fields

- Car show
- Concert
- Station
- Events
- House of Worship
- Showroom
- Corporate
- DOOH
- School
- Shopping mall
- Stadium

AirMAGLITE-V2 / Specifications

	AirMAGLITE-V2-5.2	AirMAGLITE-V2-7.8*	AirMAGLITE-V2-8.9*	AirMAGLITE-V2-10.4*
Physical Pitch	5.2 mm	7.8 mm	8.9 mm	10.4 mm
Pixel Configuration	SMD	SMD	SMD	SMD
Pixel Density	36,864 pixels/m ² 18,432 pixels/panel	16,384 pixels/m ² 8,192 pixels/panel	12,544 pixels/m ² 6,272 pixels/panel	9,216 pixels/m ² 4,608 pixels/panel
Module Dimensions (mm)	250 × 500	250 × 500	250 × 500	250 × 500
Panel Dimensions (W × H × D) (mm)	500 × 1,000 × 81	500 × 1,000 × 81	500 × 1,000 × 81	500 × 1,000 × 81
No. of Modules Per Panel (W × H)	2 × 2	2 × 2	2 × 2	2 × 2
Physical Resolution of Module (W × H)	48 × 96	32 × 64	28 × 56	24 × 48
Physical Resolution of Panel (W × H)	96 × 192	64 × 128	56 × 112	48 × 96
Weight Per Panel	9.3±0.3 kg/panel	9.3±0.3 kg/panel	9±0.3 kg/panel	9±0.3 kg/panel
Weight Per m ²	18.6±0.6 kg/m ²	18.6±0.6 kg/m ²	18±0.6 kg/m ²	18±0.6 kg/m ²
Angle	0°,±2.5°,±5°	0°,±2.5°,±5°	0°,±2.5°,±5°	0°,±2.5°,±5°
Processing	14-16 bit	14-16 bit	14-16 bit	14-16 bit
Colours	281 trillion	281 trillion	281 trillion	281 trillion
Contrast Ratio	3,000 : 1	3,000 : 1	3,000 : 1	3,000 : 1
Average Power Consumption	110 - 165 w/panel	110 - 165 w/panel	110 - 165 w/panel	110 - 165 w/panel
Power Consumption (Max)	330 w/panel	330 w/panel	330 w/panel	330 w/panel
Operating Temp/Humidity	-20 - 50°C / 10% - 90%	-20 - 50°C / 10% - 90%	-20 - 50°C / 10% - 90%	-20 - 50°C / 10% - 90%
Storage Temp/Humidity	-30 - 60°C / 10% - 95%	-30 - 60°C / 10% - 95%	-30 - 60°C / 10% - 95%	-30 - 60°C / 10% - 95%
Brightness	4,500 nits	4,500 nits	4,500 nits	4,500 nits
Refresh Rate	3,840 Hz	3,840 Hz	3,840 Hz	3,840 Hz
Horizontal Viewing Angle	140°	140°	140°	140°
Vertical Viewing Angle	120°	120°	120°	120°
Expected LED Lifetime (Max)	100,000 Hrs	100,000 Hrs	100,000 Hrs	100,000 Hrs
Max Hanging	16 panels	16 panels	16 panels	16 panels
Servicing	Back	Back	Back	Back
IP Rating	IP 65	IP 65	IP 65	IP 65
Certification	CE*, EMC ClassA*,ETL*, RoHS*,CCC*	CE*, EMC ClassA*,ETL*, RoHS*,CCC*	CE*, EMC ClassA*,ETL*, RoHS*,CCC*	CE*, EMC ClassA*,ETL*, RoHS*,CCC*

*Notes: The Specifications are for reference; actual values may vary.
Shenzhen CreateLED Electronics Co.,Ltd reserves the right to modify product design, specifications,
and parameters without further notice.

Application Fields

- Car show
- Concert
- Station
- Events
- House of Worship
- Showroom
- Corporate
- DOOH
- School
- Shopping mall
- Stadium



@CreateLED



@CreateLEDInt



CreateLED



createled

www.createled.com

sales@createled.com

*Notes: The Specifications are for reference; actual values may vary.
Shenzhen CreateLED Electronics Co.,Ltd reserves the right to modify product design, specifications,
and parameters without further notice.